

MaxMotion

PERFORMANCE DATA SHEET

Meets or exceeds MEPS, as described by the US DOE in docket 10CFR431 and NRCAN's Amendment 14

Catalogue #: **MPS-6322**

HP	kW	Voltage	S.F. @ 60Hz	EFF.	P.F.	Frame	Design	L.R. Amps
0,33	0,25	575	1,15	74,0%	0,730	63	B	8

60 Hz								
FLA							Code	F.L. RPM
208	230	416	460	480	575	600		
/	/	/	/	/	0,456	/	K	3450

50 Hz								
FLA			S.F. @ 50Hz	Efficiency	Power Factor	Code	F.L. RPM	
190	380	415						
/	/	/	/	/	/	/	/	

Wgt. Lbs	PH	Duty	Insul. Class	Amb.	Elevation	Temp. Rise° C
17,6	3	Cont.	F	40°C	1000M (3300 Ft)	35

% Efficiency		% Power Factor		Torque		Winding Resist. Ω	Safe Cold Start (Secs)
Full Load:	74,0%	Full Load:	0,73	Full Load Ft/Lbs	0,5		
3/4 Load:	71,0%	3/4 Load:	0,62	Locked Rotor %	250	/	12
1/2 Load:	64,4%	1/2 Load:	0,48	Break Down %	347	/	12

Rotor Inertia Wk2 Lb-Ft2	Max Load Inertia Wk2 Lb-Ft2	Shaft Material	Frame Material	DE Bracket Type	ODE Bracket Type	Enclosure	NEMA Rating	Lead Wire Size
/	/	Stainless Steel 304				TENV	IP66	0

Ball Bearings		Grease	Mount Type	Orientation	Paint	Sound Pressure @ 3FT	Sound Power
DE	ODE						
6202	6202	Sealed Bearings	Rigid	Horizontal	-	/	/

Inverter Duty. Motor meets MG1 parts 31.4.4.2	Constant Torque Range	Variable Torque Range	Constant HP RPM
	10:1	20:1	/

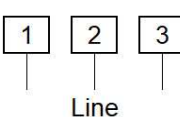
WIRING CONNECTION DIAGRAM :	D	Nema C (IEC L) Dimension (mm)	242 mm
63 - 132, Single Voltage, DOL, 3 Leads WYE Connection 575 VAC 3 phase 			

Date: 2019-01-29
 Customer: _____
 Contact: _____
 Submitter: J.C. Lavallée

Catalogue #: **MPS-6322**

Meets or exceeds MEPS, as described by the US DOE in docket 10CFR431 and NRCan's Amendment 14

HP	VAC	RPM	Enclosure	Frame	Frequency	Design	Poles	LR Code Letter	Insulation Class	Temp. Rise °C
0,33	575	3450	TENV	63	60	B	2	K	F	35

	0Hz	6Hz	15Hz	30Hz	45Hz	60Hz	75Hz	90Hz	105Hz	120Hz
Amps	0,456	0,456	0,456	0,456	0,456	0,456	0,456	0,456	0,456	0,456
RPM	0	345	862,5	1725	2587,5	3450	4312,5	5175	6037,5	6900
Torq ft.lb	0,40	0,40	0,50	0,50	0,50	0,50	0,40	0,33	0,29	0,25
Peak Tq ft.lb	0,69	1,37	1,37	1,37	1,37	1,37	1,10	0,92	0,79	0,69
HP	0	0,0	0,1	0,2	0,2	0,3	0,3	0,3	0,3	0,3

	Locked Rotor	Pull-Up	Breakdown	Rated Load	Idle	Duty	S. F.	Ambient	Elevation	dBa @ 1M
Speed (RPM)	0,0	1512	2880	3450	3600	Continuous	1,15	40°C	3,300 ft	/
Current (Amps)	8,0	6,8	4,8	0,5	0,3	VFD Rating: Meets MG1 parts 31.4.4.2				
Torque (ft-lbs)	1,3	1,1	1,7	0,5	0,0					

Motor Speed Data

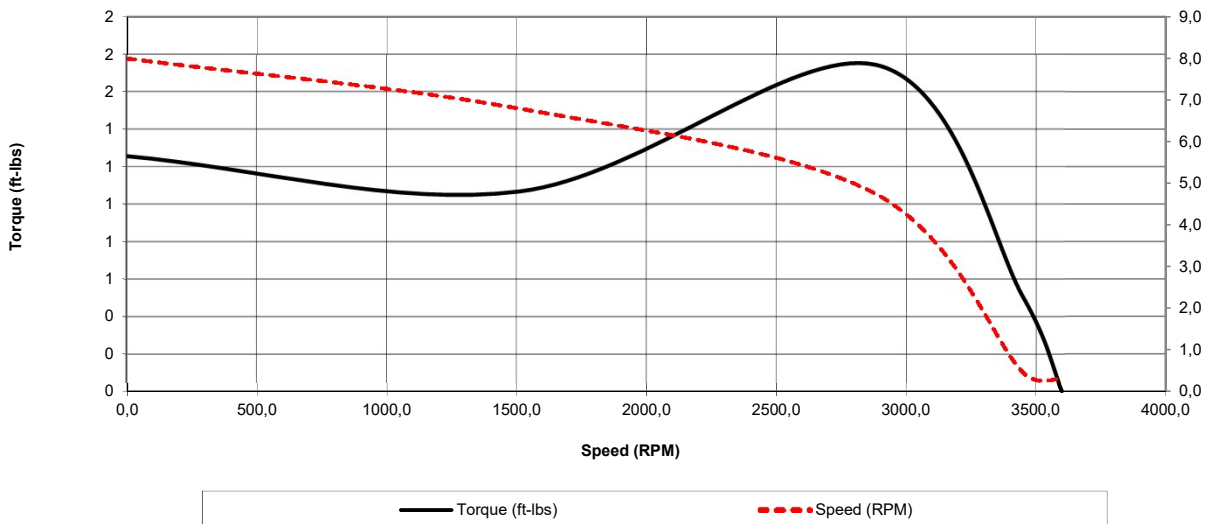

Motor Torque Capability vs RPM

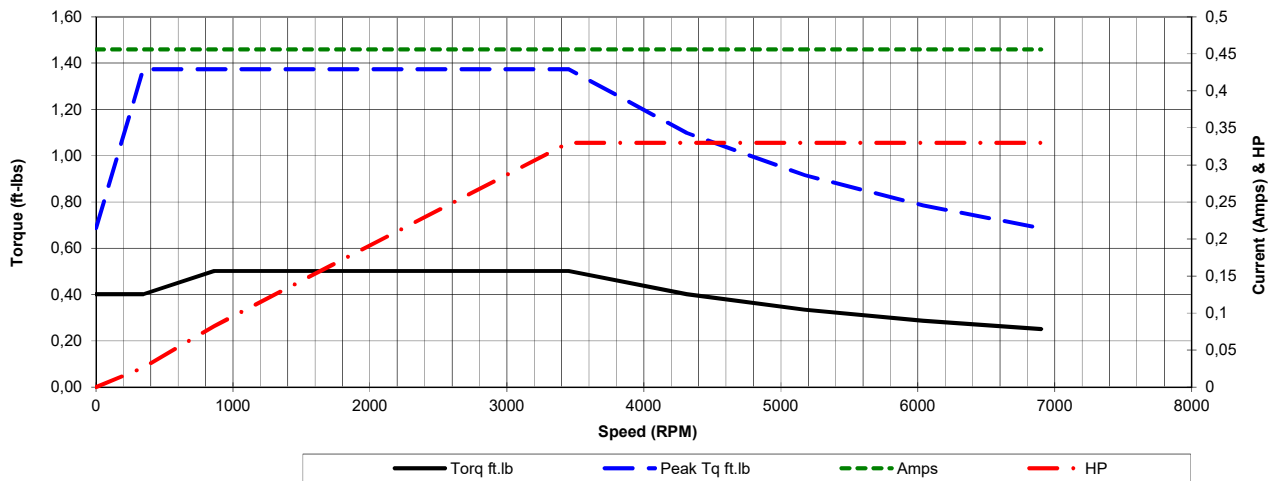

Date: 2019-01-29
 Customer: _____
 Contact: _____
 Submittee: J.C. Lavallée

Catalogue #: **MPS-6322**

Meets or exceeds MEPS, as described by the US DOE in docket 10CFR431 and NRCan's Amendment 14

HP	VAC	RPM	Enclosure	Frame	Frequency	Design	Poles	LR Code Letter	Insulation Class	Temp. Rise °C
0,33	575	3450	TENV	63	60	B	2	K	F	35

Load %	0%	25%	50%	75%	100%	125%	150%
Amps	0,32	0,35	0,37	0,40	0,46	0,57	0,68
Torq ft/lbs	0	0,12	0,25	0,37	0,50	0,63	0,77
RPM	0	3562,5	3525	3487,5	3450	3412,5	3375
Eff	0	56,46	64,38	70,97	74,00	72,80	70,72
PF	0	31,4	47,523	61,685	73,0	74,5	76,7

	Locked Rotor	Pull-Up	Breakdown	Rated Load	Idle	Duty	S. F.	Ambient	Elevation	dBA @ 1M
Speed (RPM)	0	1512	2880	3450	3600	Continuous	1,15	40°C	3,300 ft	/
Current (Amps)	8	6,8	4,8	0,456	0,32376	VFD Rating: Meets MG1 parts 31.4.4.2				
Torque (ft-lbs)	1,26	1,07	1,74	0,50	0,0	C.T.	10:1	V.T.	20:1	

Motor Speed Data

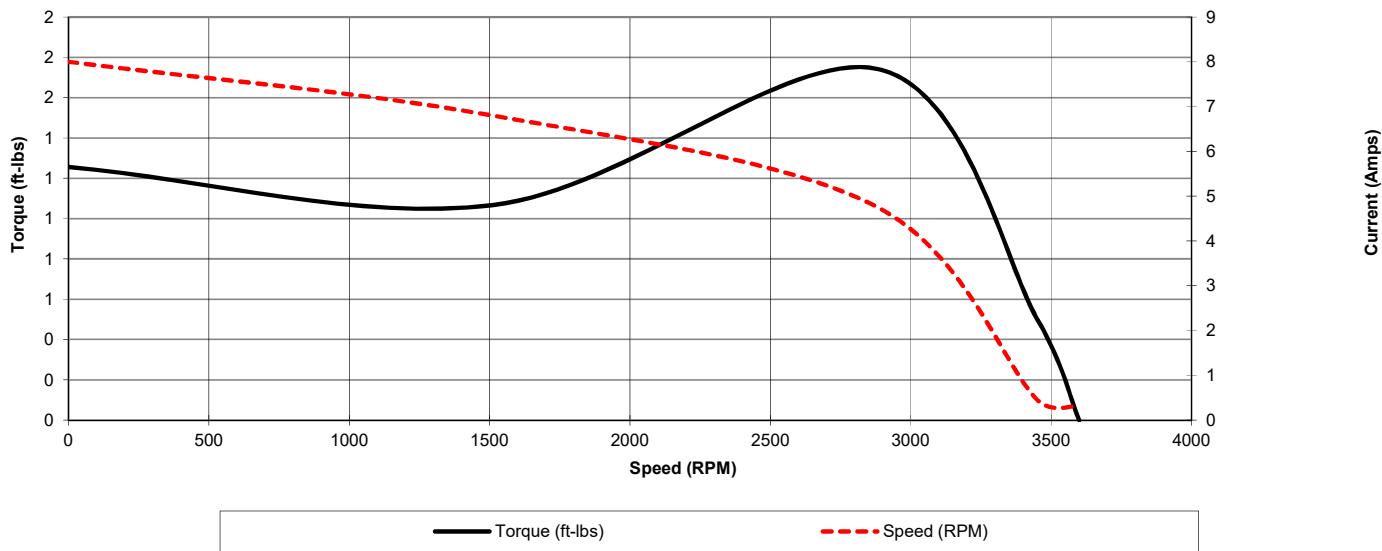

440T, 480T Dual Voltage DOL 3 Leads WYE Connection

Motor Load Data

